

Testing Optical Fibre Infrastructures

Prepared and delivered for



Bisham Abbey
20th March 2001



AGENDA

- Introduction
- OF: Testing Philosophies
- Test Methods
- Break
- Quality Planning
- Close

Mike Gilmore

The Cabling Partnership
www.it-cabling.com
e-Ready Building
www.e-readybuilding.com
PO Box MT65, LEEDS, LS17 8YD, United Kingdom
Tel: +44 (0) 113 232 3721 Fax: +44 (0) 113 232 3724

Mike Gilmore

 ISO/IEC JTC1 SC25 Secretary: WG3: Generic Cabling Member: Project Team: SOHO	 BSI Chairman TCT7/-1: IT Cabling Chairman TCT7/-3: IT Cabling
 CENELEC 50173 Ed.2 (2002) Convenor: TC215 WG1: IT Cabling	Fibreoptic Industry Association Standards Director Technical Director



The Cabling Partnership e-Ready Building
Next Generation IT infrastructures

FIA Documentation Update

AGENDA

- Introduction
- OF: Testing Philosophies
- Test Methods
- Break
- Quality Planning
- Close

DESIGN		
FIA-TSD-2000-1-1	OPTICAL FIBRE CABLING: LAN APPLICATION SUPPORT GUIDE	JANUARY 2001
	Revision to include mode conditioning cords and 10GBASE-xyz	JANUARY 2002
INSTALLATION		
FIA-TSD-2000-4-2-1	TESTING OF INSTALLED CABLING: ATTENUATION USING LSPM EQUIPMENT	JANUARY 2002
SAFETY		
FIA-TSD-2000-5-1	OPTICAL POWER: SAFETY LEVELS	DECEMBER 2001
FIA-TSD-2000-5-2	OPTICAL FIBRE: HANDLING OF PROCESSING CHEMICALS	
FIA-TSD-2000-5-3	OPTICAL FIBRE: DISPOSAL OF WASTE	
MODELLING TOOLS		
	CABLING STRUCTURES COST MODEL	DECEMBER 2001



© 2001 The Cabling Partnership www.it-cabbling.com www.e-readybuilding.com
P. O. Box MT65, LEEDS, LS17 8YD, United Kingdom Tel: +44 (0) 113 232 3721 Fax: +44 (0) 113 232 3724

The Cabling Partnership e-Ready Building
Next Generation IT infrastructures

OF - Testing Philosophies

AGENDA

- Introduction
- OF: Testing Philosophies
- Test Methods
- Break
- Quality Planning
- Close

- Reference Points
- General Implementations
- The Alternative Approaches
- Testing Regimes
- Light Source - Power Meters
- Equipment Grades (FIA)
- Test Cords
 - Launch conditions
 - MMF Mandrel Wrap
 - The Importance of Cords
- LSPM Measurement Accuracy
- Measurement Error
- Typical Results
- Cabling Configurations
- Impact of Incorrect Methods



© 2001 The Cabling Partnership www.it-cabbling.com www.e-readybuilding.com
P. O. Box MT65, LEEDS, LS17 8YD, United Kingdom Tel: +44 (0) 113 232 3721 Fax: +44 (0) 113 232 3724

AGENDA

- Introduction
- OF: Testing Philosophies
- Test Methods
- Break
- Quality Planning
- Close

Reference Points

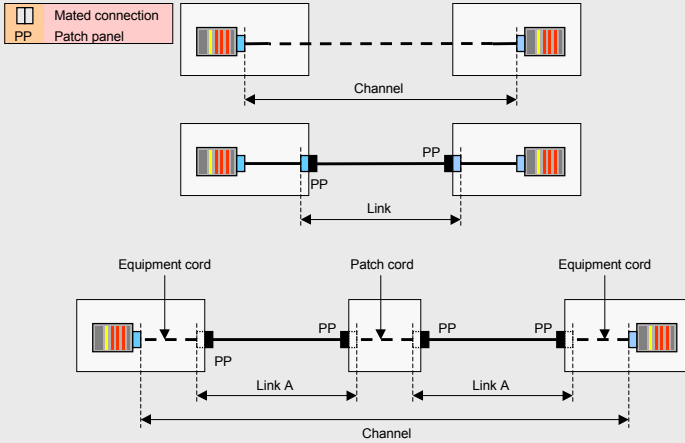

AGENDA

- Introduction
- OF: Testing Philosophies
- Test Methods
- Break
- Quality Planning
- Close

General Implementations

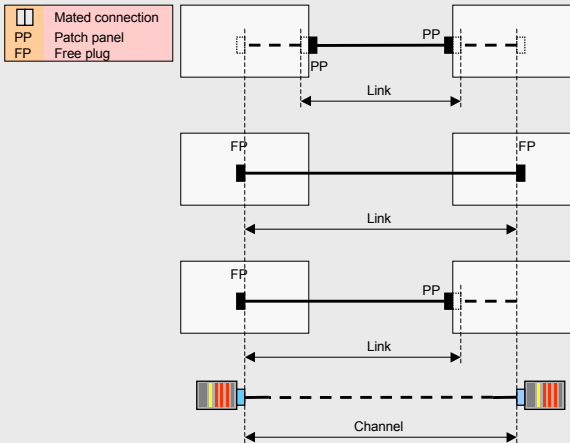

AGENDA

- Introduction
- OF: Testing Philosophies
- Test Methods
- Break
- Quality Planning
- Close

The Alternative Approaches

	Optical power budget (dB)		
	MMF	1300nm	SMF
"Channel" approach	APPLICATION	850nm	1310nm
	ISO/IEC 8802-3: 10BASE-FL/FB	12,5 (6,8)	
	ISO/IEC 8802-5: TR 4/16 Mbit/s	13,0 (8,0)	
	ISO/IEC 9314-3 FDDI		11,0 (6,0)
	ISO/IEC DIS 9314-4 FDDI		10,0
	ISO/IEC 8802-3: 100BASE-FX		11,0 (6,0)
	TR 100 Mbit/s		11,0 (6,0)
	CD 14165-1: Fibre Channel-1062	4,0	6,0
	IEEE 802-3: 1000BASE-SX	2,6 (3,56)	
	IEEE 802-3: 1000BASE-LX	2,35	5,0

	Maximum values	x dB	y dB	z dB
"Overall loss" approach				
"Component loss" approach				



AGENDA

- Introduction
- OF: Testing Philosophies
- Test Methods
- Break
- Quality Planning
- Close

Testing Regimes

TEST REGIME	ITEMS UNDER TEST	TESTING APPROACH	TEST TOOL
Component Acceptance	Cables	Component loss	OTDR
	Cords	Overall loss	LSPM
Legacy Cabling Acceptance	Links and channels	Overall loss	LSPM
		Component loss	OTDR
Partial Completion Tests	Links	Component loss	OTDR
Installed Cabling Acceptance	Links and channels	Overall loss	LSPM
		Component loss	OTDR
Fault Diagnosis	Links and channels	Component loss	OTDR



AGENDA

- Introduction
- OF: Testing Philosophies
- Test Methods
- Break
- Quality Planning
- Close

Light Source - Power Meters

LSPM = Light Source - Power Meter

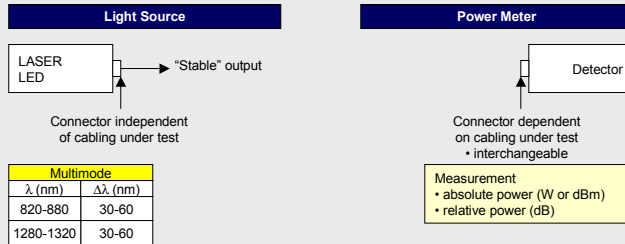

AGENDA

- Introduction
- OF: Testing Philosophies
- Test Methods
- Break
- Quality Planning
- Close

Equipment Grades (FIA)

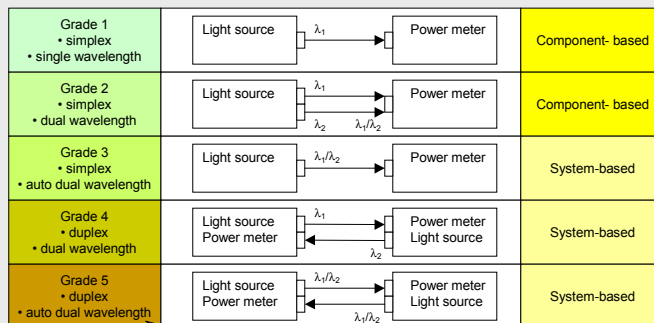

Includes single location Grade 3



AGENDA

- Introduction
- OF: Testing Philosophies
- Test Methods
- Break
- Quality Planning
- Close

Test Cord Launch Conditions

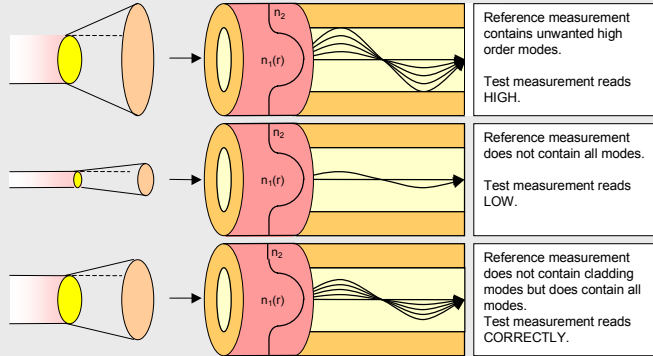

AGENDA

- Introduction
- OF: Testing Philosophies
- Test Methods
- Break
- Quality Planning
- Close

MMF Mandrel Wrap

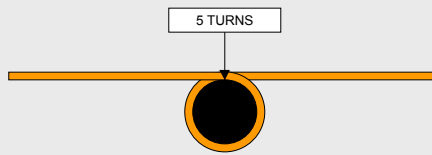

USA		EU		Other	
MMF: not applicable		MMF: EN 50346 6MP		MMF: ANSI/TIA/EIA B.1	
			Mandrel Diameter		Mandrel Diameter
50/125	Cable	18	50/125	Cable	25
50/125	SCOF	15	50/125	SCOF	22
62.5/125	Cable	20	62.5/125	Cable	20
62.5/125	SCOF	17	62.5/125	SCOF	17



AGENDA

- Introduction
- OF: Testing Philosophies
- Test Methods
- Break
- Quality Planning
- Close

The Importance of Cords

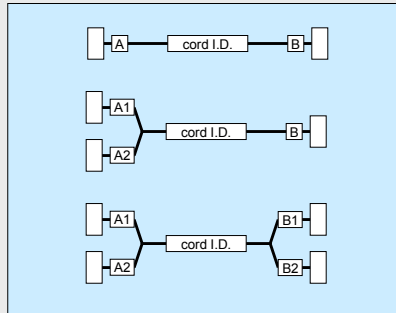

AGENDA

- Introduction
- OF: Testing Philosophies
- Test Methods
- Break
- Quality Planning
- Close

LSPM Measurement Accuracy

CORE		$Loss = -10 \log_{10} \left[\left(\frac{d_2}{d_1} \right)^2 \right]$ dB from large core to small core (0 dB from small to large)
CORE		$Loss = -10 \log_{10} \left[\left(\frac{NA_2}{NA_1} \right)^2 \right]$ dB from large NA to small NA (0 dB from small to large)
CORE		$Loss = -10 \log_{10} \left[\frac{1}{90} \tan^{-1} \left(\frac{de}{x} \right) - \frac{2xe}{\pi d} \right]$ dB in both directions $e = \left[1 - \left(\frac{x}{d} \right)^2 \right]^{0.5}$



AGENDA

- Introduction
- OF: Testing Philosophies
- Test Methods
- Break
- Quality Planning
- Close

LSPM Measurement Accuracy

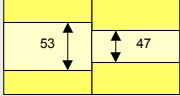
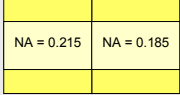
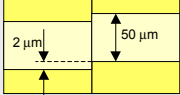
CORE		$Loss = -10 \log_{10} \left[\left(\frac{47}{53} \right)^2 \right]$	= -1.04 dB	Applied statistics and real manufacturing tolerances suggest combined value < -0.35 dB per joint
CORE		$Loss = -10 \log_{10} \left[\left(\frac{0.185}{0.215} \right)^2 \right]$	= -1.30 dB	
CORE		Loss	= -0.47 dB	

Measurement accuracy of LSPM systems = 0.7 dB plus other mismatches



AGENDA

- Introduction
- OF: Testing Philosophies
- Test Methods
- Break
- Quality Planning
- Close

Measurement Error

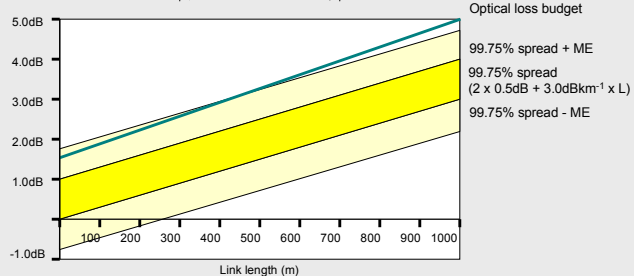
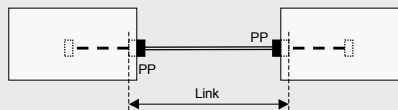

AGENDA

- Introduction
- OF: Testing Philosophies
- Test Methods
- Break
- Quality Planning
- Close

Typical Results

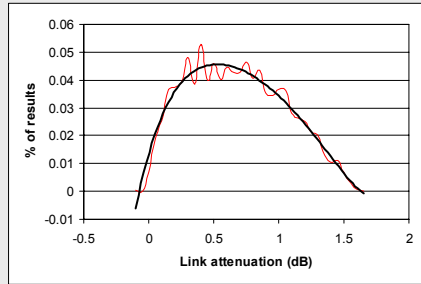

AGENDA

- Introduction
- OF: Testing Philosophies
- Test Methods
- Break
- Quality Planning
- Close

Cabling Configurations

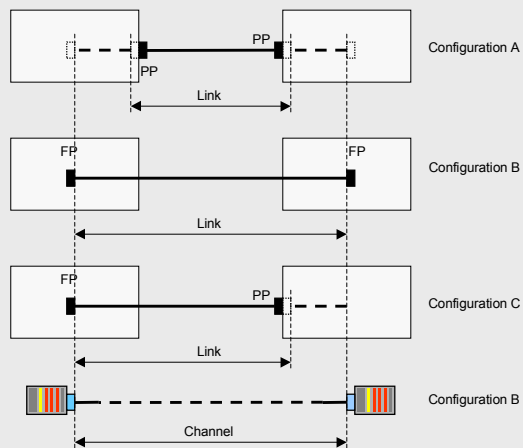

The Cabling Partnership e-Ready Building
Next Generation IT infrastructures

Impact of Incorrect Methods

AGENDA

- Introduction
- OF: Testing Philosophies
- Test Methods
- Break
- Quality Planning
- Close

INSTALLED LINK	METHOD APPLIED	RESULT
CONFIGURATION A	CONFIGURATION A	CORRECT
	CONFIGURATION B	LOW BY 2 CONNECTIONS
	CONFIGURATION C	LOW BY 1 CONNECTION
CONFIGURATION B	CONFIGURATION A	HIGH BY 2 CONNECTIONS
	CONFIGURATION B	CORRECT
	CONFIGURATION C	HIGH BY 1 CONNECTION
CONFIGURATION C	CONFIGURATION A	HIGH BY 1 CONNECTION
	CONFIGURATION B	LOW BY 1 CONNECTION
	CONFIGURATION C	CORRECT

INSTALLED CHANNEL	METHOD APPLIED	RESULT
CONFIGURATION B	CONFIGURATION A	HIGH BY 2 CONNECTIONS
	CONFIGURATION B	CORRECT
	CONFIGURATION C	HIGH BY 1 CONNECTION

All measurements are subject to the fundamental accuracy of the technique



© 2001 The Cabling Partnership P. O. Box MT65, LEEDS, LS17 8YD, United Kingdom Tel: +44 (0) 113 232 3721 Fax: +44 (0) 113 232 3724

The Cabling Partnership e-Ready Building
Next Generation IT infrastructures

Test Methods

AGENDA

- Introduction
- OF: Testing Philosophies
- Test Methods
- Break
- Quality Planning
- Close

- LSPM Test Methods
 - Configuration A
 - Configuration B
 - Configuration C
- Duplex Cabling
 - Link Configuration A
 - Equipment Grade 2
 - Equipment Grades 4,5



© 2001 The Cabling Partnership P. O. Box MT65, LEEDS, LS17 8YD, United Kingdom Tel: +44 (0) 113 232 3721 Fax: +44 (0) 113 232 3724

AGENDA

- Introduction
- OF: Testing Philosophies
- Test Methods
- Break
- Quality Planning
- Close

LSPM Test Methods

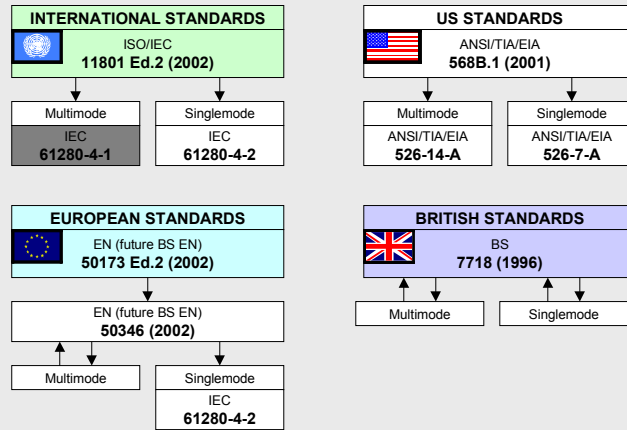

AGENDA

- Introduction
- OF: Testing Philosophies
- Test Methods
- Break
- Quality Planning
- Close

LSPM Test Method Glossary

ARENA	REFERENCE	TITLE
IEC	61280-4-1	Fibre optic communication subsystem basic test procedures - Part 4-1: Fibre optic cable plant - Multimode fibre optic cable plant attenuation
IEC	61280-4-2	Fibre optic communication subsystem basic test procedures - Part 4-2: Fibre optic cable plant - Single-mode fibre optic cable plant attenuation
EN	50346	Information Technology - Testing of installed cabling
TIA/EIA	526-14-A	OFSTP-14A Optical Power Loss Measurement of Installed Multimode Fiber Cable Plant (ANSI/TIA/EIA-526-14A-98)
TIA/EIA	526-7	OFSTP-7 Measurement of Optical Power Loss of Installed Single-Mode Fiber Cable Plant (ANSI/TIA/EIA-526-7-98)



AGENDA

- Introduction
- OF: Testing Philosophies
- Test Methods
- Break
- Quality Planning
- Close

Configuration A Test Method

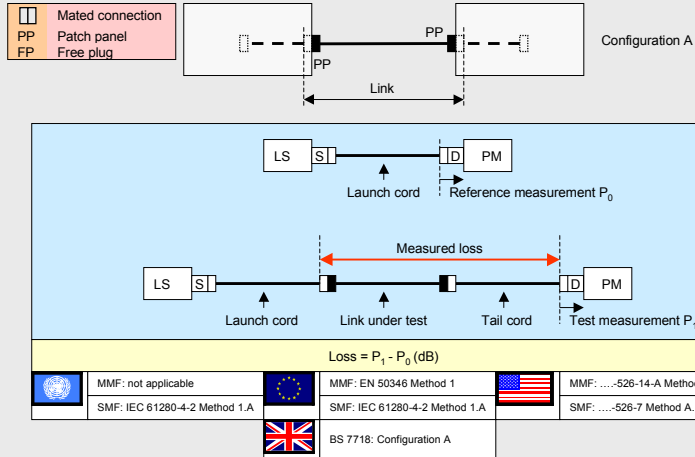

AGENDA

- Introduction
- OF: Testing Philosophies
- Test Methods
- Break
- Quality Planning
- Close

Configuration B Test Method

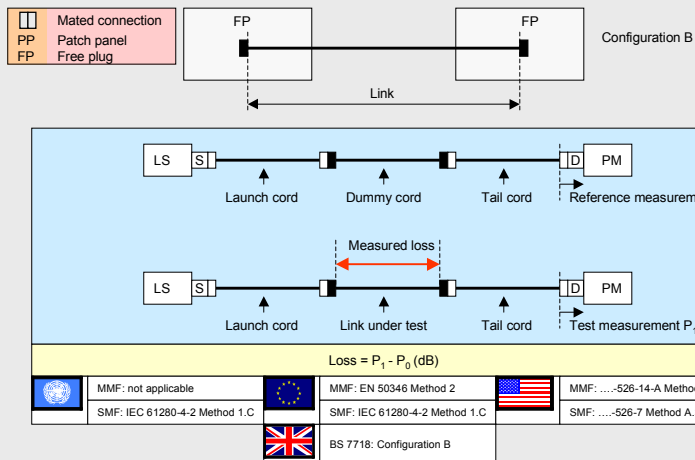

AGENDA

- Introduction
- OF: Testing Philosophies
- Test Methods
- Break
- Quality Planning
- Close

Configuration C Test Method

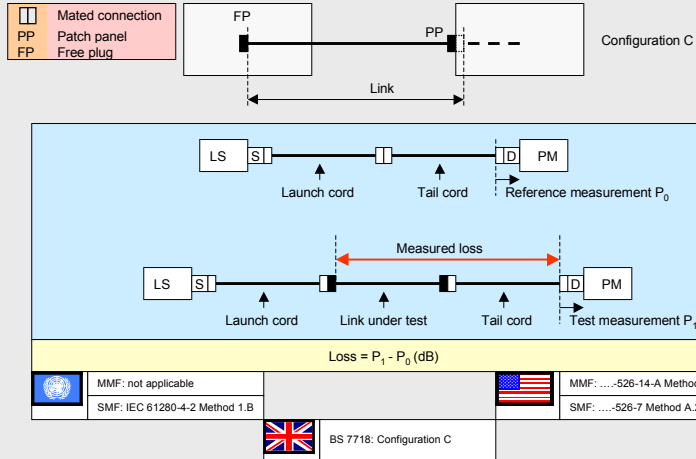

AGENDA

- Introduction
- OF: Testing Philosophies
- Test Methods
- Break
- Quality Planning
- Close

Duplex Cabling

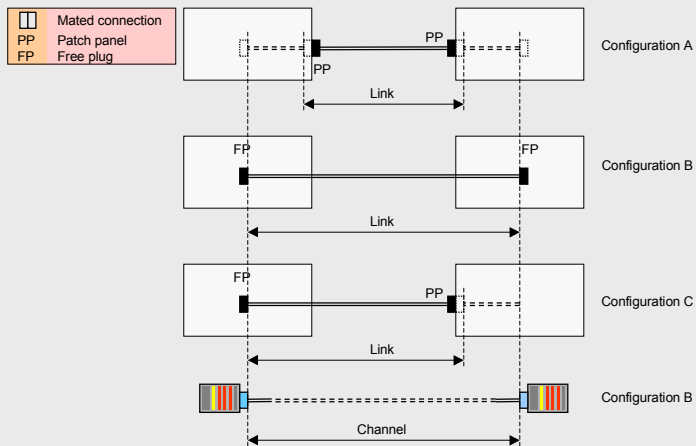

AGENDA

- Introduction
- OF: Testing Philosophies
- Test Methods
- Break
- Quality Planning
- Close

Link Configuration A - Grade 2

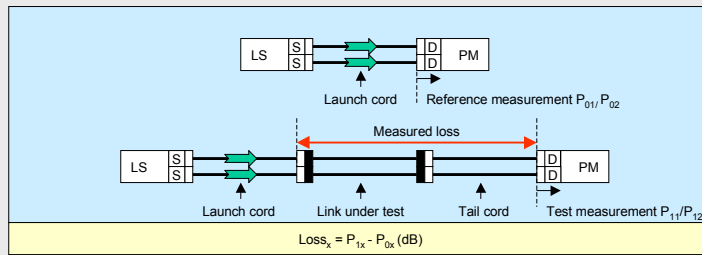
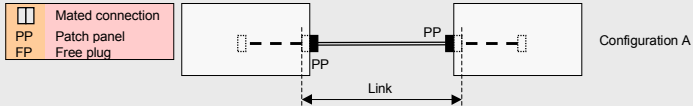

AGENDA

- Introduction
- OF: Testing Philosophies
- Test Methods
- Break
- Quality Planning
- Close

Link Configuration A - Grade 4,5

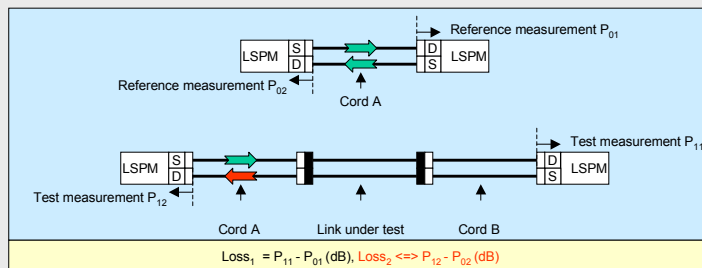
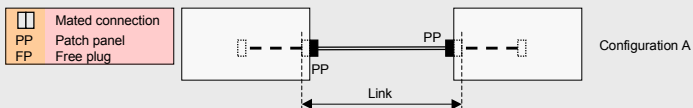

Test measurement P_{12} will be influenced by removal of Cord A from RH LSPM
 Unless LSPM guarantees that coupled power into Cord B is the same as Cord A, measurement error may occur



AGENDA

- Introduction
- OF: Testing Philosophies
- Test Methods
- Break
- Quality Planning
- Close

Channel Test - Grade 4,5

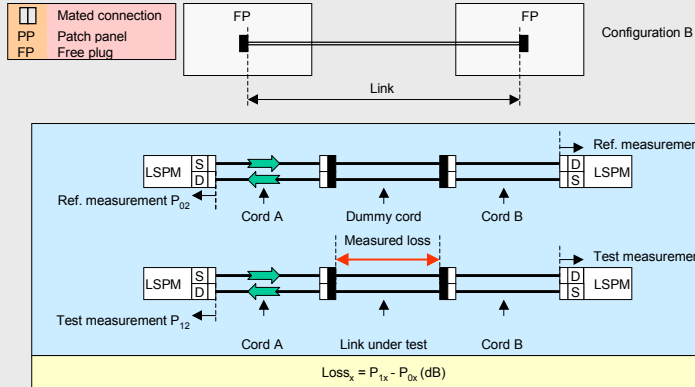

AGENDA

- Introduction
- OF: Testing Philosophies
- Test Methods
- Break
- Quality Planning
- Close

Link Configuration A - Grade 4,5

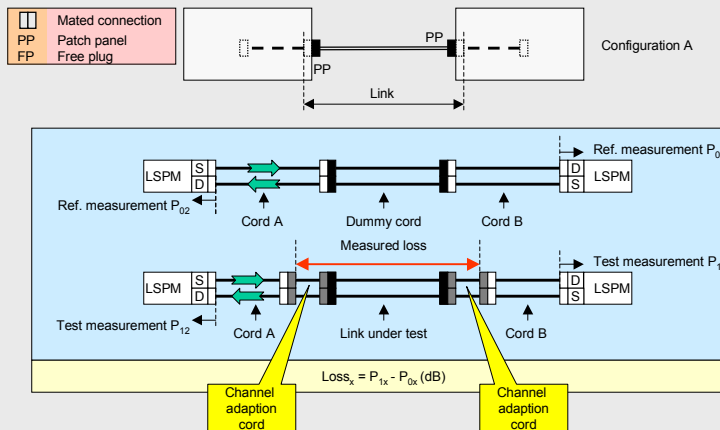

AGENDA

- Introduction
- OF: Testing Philosophies
- Test Methods
- Break
- Quality Planning
- Close

Symmetric and Asymmetric

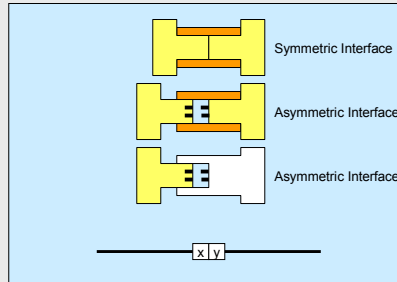

AGENDA

- Introduction
- OF: Testing Philosophies
- Test Methods
- Break
- Quality Planning
- Close

Configuration A Link Testing

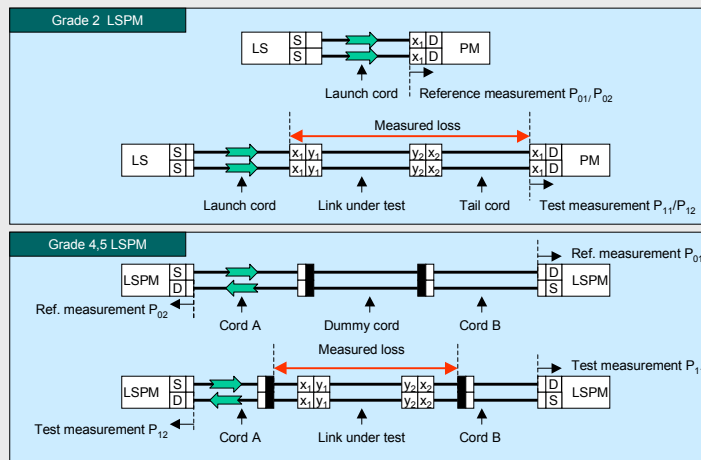

AGENDA

- Introduction
- OF: Testing Philosophies
- Test Methods
- Break
- Quality Planning
- Close

Channel Testing

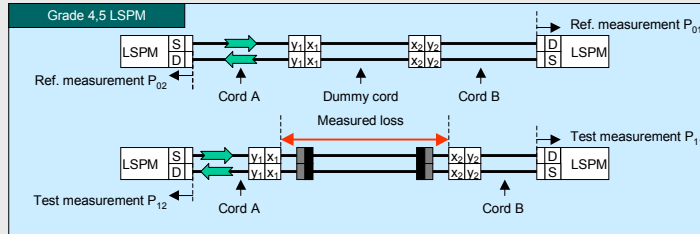

AGENDA

- Introduction
- OF: Testing Philosophies
- Test Methods
- Break
- Quality Planning
- Close

Break



The Cabling Partnership e-Ready Building
Next Generation IT infrastructures

Quality Planning

AGENDA

- Introduction
- OF: Testing Philosophies
- Test Methods
- Break
- Quality Planning
- Close

Optical Power Budget/CIL
Optical Fibre Cabling Classes
Quality Plan
Pass/Fail Indicators
LASER LSPM Equipment
OTDR vs. LSPM

FIA
The Fibreoptic Industry Association

© 2001 The Cabling Partnership P. O. Box MT65, LEEDS, LS17 8YD, United Kingdom Tel: +44 (0) 113 232 3721 Fax: +44 (0) 113 232 3724

The Cabling Partnership e-Ready Building
Next Generation IT infrastructures

Optical Power Budget/CIL

AGENDA

- Introduction
- OF: Testing Philosophies
- Test Methods
- Break
- Quality Planning
- Close

Application			Optical Fibre			
Mb/s	Network	λ	50/125 (OM2)		62.5/125 (OM1)	
			Max. length (m)	OPB max. (dB)	Max. length (m)	OPB max. (dB)
4	Token Ring	850 nm	1857 ¹	8.0	2000	13.0
10	Ethernet		1514 ¹	6.8	2000	12.5
16	Token Ring		1857 ¹	8.0	2000	13.0
100	Ethernet	1300 nm	2000	6.0	2000	11.0
1000	Ethernet	850 nm	550	3.56	275	2.6
1000	Ethernet	1300 nm	550	2.35	550	2.35
10000	Ethernet	850 nm	82	1.80	33	1.60
10000	Ethernet	CWDM/850	300	1.96	300	1.96
			50/125 (OM3)			
10000	Ethernet	850 nm	300	2.59		

¹ Calculated values using 1.5dB of connecting hardware losses

FIA
The Fibreoptic Industry Association

© 2001 The Cabling Partnership P. O. Box MT65, LEEDS, LS17 8YD, United Kingdom Tel: +44 (0) 113 232 3721 Fax: +44 (0) 113 232 3724

AGENDA

- Introduction
- OF: Testing Philosophies
- Test Methods
- Break
- Quality Planning
- Close

Optical Fibre Cabling Classes

		Optical fibre channel class			
		OF-300	OF-500	OF-2000	
Parameter					
Attenuation		CLC/IS	CLC/IS	CLC/IS	

		Maximum attenuation (dB)			
		Multimode		Singlemode	
		850nm	1300nm	1310nm	1550nm
Class	OF-300	2,55	1,95	1,80	1,80
	OF-500	3,25	2,25	2,00	2,00
	OF-2000	8,50	4,50	3,50	3,50



AGENDA

- Introduction
- OF: Testing Philosophies
- Test Methods
- Break
- Quality Planning
- Close

Quality Plan

The Quality Plan details the:

- test procedures to be used
- actions to be taken in the event of marginal results (i.e. results that lie within the measurement accuracy but outside the expected values).

Specifically the Quality Plan shall contain information about the following:

- the test equipment and test cords to be used;
- the need for bi-directional testing;
 - This may be a specific customer requirement but there is no need for bi-directional testing providing that the correct methods and cords are used
- transmission wavelength;
 - The Installation Specification defines the wavelength(s) at which the cabling is to be tested. If the Installation Specification refers to external standards such as ISO/IEC 11801, EN 50173 or ANSI/TIA/EIA-568B then these standards shall be consulted to determine their requirements;
- the administration of the test;
 - detailing how each test is to be referenced/identified;
 - detailing how the test configuration is to be recorded;
- the treatment of marginal results;
 - proposals for re-testing with different test leads and the use of a statistical approach; if the result continues to be marginal then it may be necessary to investigate the cause of the loss by means of an OTDR (see FIA-TSD-2000-4-2-2) to determine if the problem lies within the cable or the connections.



AGENDA

- Introduction
- OF: Testing Philosophies
- Test Methods
- Break
- Quality Planning
- Close

Pass/Fail Indicators

Test equipment that not only measures but also ADJUDICATES

Application support based upon:

- length (requiring the modal bandwidth of the optical fibre to be input);
- measured link/channel loss.

Cabling performance against calculation of optical loss budget based upon:

- number and type of joints
- length;
- measured link/channel loss.

PASS/FAIL INDICATORS ARE VERY SUSCEPTIBLE TO SHORT LENGTH SYNDROME (measurement error)



AGENDA

- Introduction
- OF: Testing Philosophies
- Test Methods
- Break
- Quality Planning
- Close

LASER LSPM Equipment

There is an argument to suggest that MMF cabling to support LASER-based applications should be tested with LASER sources

Reference measurement does not contain all modes.
Test measurement reads LOW.

Test results can vary with test lead handling.

Unless explicitly allowed and documented such equipment should not be used



The Cabling Partnership e-Ready Building
Next Generation IT infrastructures

OTDR vs. LSPM

AGENDA

- Introduction
- OF: Testing Philosophies
- Test Methods
- Break
- Quality Planning
- Close

SHORT LENGTH SYNDROME
calls LSPM measurements into question
(unless measurement error is "allowed for" in adjudication)

OTDRs can be used to assess and measure individual components
(subject to appropriate techniques)

COMPONENT UP VERIFICATION MAY BECOME MORE COMMON

FIA
The Fibreoptic Industry Association

© 2001 The Cabling Partnership P. O. Box MT65, LEEDS, LS17 8YD, United Kingdom Tel: +44 (0) 113 232 3721 Fax: +44 (0) 113 232 3724 www.it-cabling.com www.e-readybuilding.com

The Cabling Partnership e-Ready Building
Next Generation IT infrastructures

Conclusions

AGENDA

- Introduction
- OF: Testing Philosophies
- Test Methods
- Break
- Quality Planning
- Close

READ THE CABLING SPECIFICATION

KNOW YOUR LIMITS
• which standard?
• which issue?

UNDERSTAND THE MARGINS
• undertake a channel design review
• make sure the client understands it

PLAN FOR FAILURE
• can "FAIL"s be expected?
• under which conditions?
• what happens next?
• agree process with client

TEST CORDS - TEST CORDS
TEST CORDS - TEST CORDS

FIA
The Fibreoptic Industry Association

© 2001 The Cabling Partnership P. O. Box MT65, LEEDS, LS17 8YD, United Kingdom Tel: +44 (0) 113 232 3721 Fax: +44 (0) 113 232 3724 www.it-cabling.com www.e-readybuilding.com

Testing Multimode Optical Fibre Infrastructures

Prepared and delivered for



Bisham Abbey
20th March 2002