

The New Generation of Optical Fibre Components

Prepared and delivered for



Edinburgh Hilton
11th October 2001



AGENDA

- Introduction
- A Standards Update
- Optical Fibre Categories
- Backwards Compatibility
- 10GBASE-xyz
- SFF Connecting Hardware
- Testing the New Cabling
- Question Time
- Close

Mike Gilmore

The Cabling Partnership
www.it-cabling.com
e-Ready Building
www.e-readybuilding.com
PO Box MT65, LEEDS, LS17 8YD, United Kingdom
Tel: +44 (0) 113 232 3721 Fax: +44 (0) 113 232 3724

Mike Gilmore

 ISO/IEC JTC1 SC25 Secretary: WG3: Generic Cabling Member: Project Team: SOHO	 BSI Chairman TCT7/-/1: IT Cabling Chairman TCT7/-/3: IT Cabling
 CENELEC Convenor: TC215 WG1: IT Cabling	Fibreoptic Industry Association Standards Director Technical Director





AGENDA

- Introduction
- A Standards Update**
- Optical Fibre Categories
- Backwards Compatibility
- 10GBASE-xyz
- SFF Connecting Hardware
- Testing the New Cabling
- Question Time

Close

A Standards Update

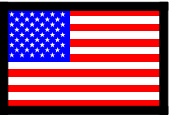
		
EN 50173 Ed.2 (2002)	ISO/IEC 11801 Ed.2 (2002)	ANSI/TIA/EIA 568 B Series
Information technology - Generic cabling systems	Information technology - Generic cabling for customer premises	Commercial building telecommunications cabling standard
<ul style="list-style-type: none"> • SE Completed • 6MP begins July, 2001 • 3MV begins Q2, 2002 • publication Q4, 2002 	<ul style="list-style-type: none"> • 2nd CD Completed • FCD NOW • FDIS Q2, 2002 • publication Q4, 2002 	<ul style="list-style-type: none"> • B.1 General Requirements <ul style="list-style-type: none"> • published • B.2 Balanced Twisted-pair Cabling <ul style="list-style-type: none"> • published • Addendum 1 <ul style="list-style-type: none"> • Category 6 <ul style="list-style-type: none"> • Draft 9a (08/01) • B.3 Optical Fibre Cabling <ul style="list-style-type: none"> • published



AGENDA

- Introduction
- A Standards Update**
- Optical Fibre Categories
- Backwards Compatibility
- 10GBASE-xyz
- SFF Connecting Hardware
- Testing the New Cabling
- Question Time

Close

FIA Documentation Update

DESIGN		
FIA-TSD-2000-1-1	OPTICAL FIBRE CABLING: LAN APPLICATION SUPPORT GUIDE	JANUARY 2001
	Revision to include mode conditioning cords and 10GBASE-xyz	JANUARY 2002
INSTALLATION		
FIA-TSD-2000-4-2-1	TESTING OF INSTALLED CABLING: ATTENUATION USING LSPM EQUIPMENT	JANUARY 2002
SAFETY		
FIA-TSD-2000-5-1	OPTICAL POWER: SAFETY LEVELS	DECEMBER 2001
FIA-TSD-2000-5-2	OPTICAL FIBRE: HANDLING OF PROCESSING CHEMICALS	
FIA-TSD-2000-5-3	OPTICAL FIBRE: DISPOSAL OF WASTE	
MODELLING TOOLS		
	CABLING STRUCTURES COST MODEL	DECEMBER 2001



AGENDA

Introduction

- A Standards Update
- Optical Fibre Categories
- Backwards Compatibility
- 10GBASE-xyz
- SFF Connecting Hardware
- Testing the New Cabling
- Question Time

Close



Optical Fibre Categories

IT CABLING STANDARDS					
		Attenuation coefficient dBkm ⁻¹ max.		Modal bandwidth MHz.km min.	
		850nm	1300nm	850nm	1300nm
ISO/IEC 11801(1995)	50/125 and 62.5/125	3.5	1.0	200	500
EN 50173 (1995)	50/125 and 62.5/125	3.5	1.0	200	500
ANSI/TIA/EIA 568A (1995)	62.5/125	3.75	1.5	160	500

OPTICAL FIBRE STANDARDS (IEC 60793-X-X)						
		Attenuation coefficient dBkm ⁻¹ max.		Modal bandwidth (OFL) MHz.km min.		
		850nm	1300nm	850nm	1300nm	
50/125	2.4	0.6	50/125 + 62.5/125	200	400	50/125 + 62.5/125
	2.5	0.8		200	600	
	2.7	1.0		160	200	
62.5/125	3.0	0.7	62.5/125	250	1000	62.5/125
	3.2	0.9		300	800	
				400	1000	

AGENDA

Introduction

- A Standards Update
- Optical Fibre Categories
- Backwards Compatibility
- 10GBASE-xyz
- SFF Connecting Hardware
- Testing the New Cabling
- Question Time

Close



OFL/LL Modal Bandwidth

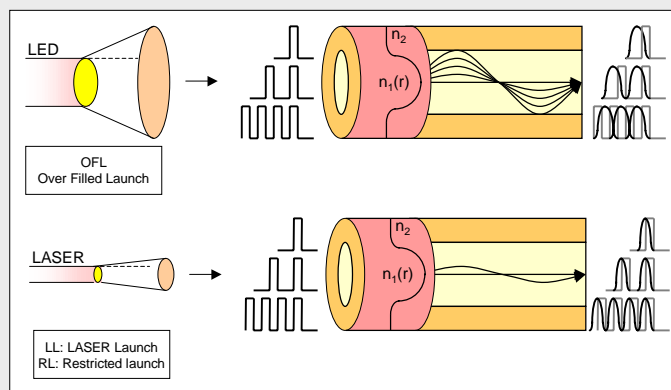



AGENDA

Introduction

- A Standards Update
- Optical Fibre Categories
- Backwards Compatibility
- 10GBASE-xyz
- SFF Connecting Hardware
- Testing the New Cabling
- Question Time

Close

Optical Fibre Categories

IT CABLING STANDARDS			
	ISO/IEC 11801 Ed. 2 (2002)		EN 50173 Ed. 2 (2002)
	2nd CDV: Document N696		BS EN 50173 Ed. 2 (2002)
			6MP Document

	Wavelength	Multimode OF			Wavelength	Singlemode OF
		OM1	OM2	OM3		
Attenuation coefficient (dBkm ⁻¹ max)	850nm	3.5			1310nm	1.0
	1300nm	1.5			1550nm	1.0
Modal bandwidth OFL (MHz.km min)	850nm	200	500	500		
	1300nm	500	500	500		
Modal bandwidth LL (MHz.km min)	850nm	ffs	ffs	2000		
	1300nm	ffs	ffs	ffs		
Propagation delay (ns.m ⁻¹ max)	850nm	5			1310nm	5
	1300nm				1550nm	





AGENDA

Introduction

- A Standards Update
- Optical Fibre Categories
- Backwards Compatibility
- 10GBASE-xyz
- SFF Connecting Hardware
- Testing the New Cabling
- Question Time

Close

Optical Fibre Categories

IT CABLING STANDARDS			
	ISO/IEC 11801 Ed. 2 (2002)		EN 50173 Ed. 2 (2002)
	FCD: Document N739		BS EN 50173 Ed. 2 (2002)
			Next draft

	Wavelength	Multimode OF			Wavelength	Singlemode OF
		OM1	OM2	OM3		
Attenuation coefficient (dBkm ⁻¹ max)	850nm	3.5			1310nm	1.0
	1300nm	1.5			1550nm	1.0
Modal bandwidth OFL (MHz.km min)	850nm	200	500	1500		
	1300nm	500	500	500		
Modal bandwidth LL (MHz.km min)	850nm	-	-	2000		
	1300nm	-	-	-		
Propagation delay (ns.m ⁻¹ max)	850nm	5			1310nm	5
	1300nm				1550nm	

Legacy OF Legacy OF





AGENDA

Introduction

- A Standards Update
- Optical Fibre Categories
- Backwards Compatibility
- 10GBASE-xyz
- SFF Connecting Hardware
- Testing the New Cabling
- Question Time

Close

Backwards Compatibility

IT CABLING STANDARDS			
	ISO/IEC 11801 Ed. 2 (2002)		EN 50173 Ed. 2 (2002)
	FCD: Document N739		BS EN 50173 Ed. 2 (2002)
No explicit requirements are stated			

Experience to date

- No processing problems splicing between OM1/OM2 and OM3
 - Insertion loss of splices between OM1/OM2 and OM3 remains OK
 - Insertion loss of connections between OM1/OM2 and OM3 remains OK
 - Testing OM3 with OM1/OM2 test leads provides logical results
- All the above assume that the 50/125µm is used



AGENDA

Introduction

- A Standards Update
- Optical Fibre Categories
- Backwards Compatibility
- 10GBASE-xyz
- SFF Connecting Hardware
- Testing the New Cabling
- Question Time

Close

10GBASE-xyz

IEEE 802.3ae (completion June 2002)

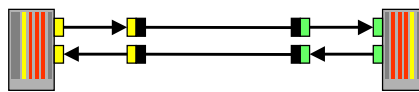

- switched operation only
- star topology
- support 10Gb/s Ethernet and 9.584640Gb/s SONET
- 2000 m, 10000 m and 40000 m over SMF
- 100 m over existing MMF

		Range	OF	λ	Cable	Protocol	
SAN	Legacy support	< 33 m	MMF	850	OM1	Serial	10GBASE-SR
		< 82 m	MMF	850	OM2	Serial	10GBASE-SR
LAN		< 300 m	MMF	850	OM3	Serial	10GBASE-SR/SW
		< 300 m	MMF	1300	OMx	CWDM	10GBASE-LX4
LM/WAN	Legacy support	< 10000 m	SMF	1310	OS1	Serial	10GBASE-LR/LW
		< 40000 m	SMF	1550	OS1	Serial	10GBASE-ER/EW



AGENDA

Introduction

- A Standards Update
- Optical Fibre Categories
- Backwards Compatibility
- 10GBASE-xyz
- SFF Connecting Hardware
- Testing the New Cabling
- Question Time

Close

100Mb/s Implementation

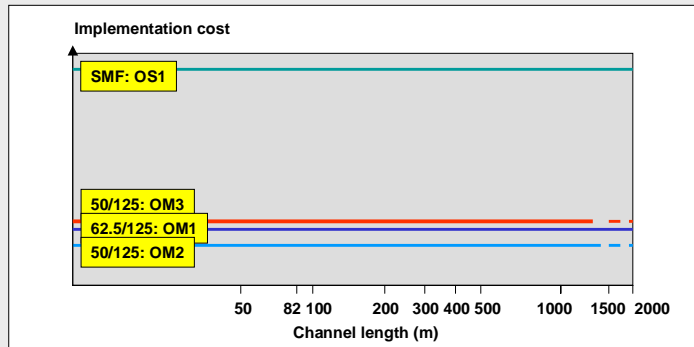

AGENDA

Introduction

- A Standards Update
- Optical Fibre Categories
- Backwards Compatibility
- 10GBASE-xyz
- SFF Connecting Hardware
- Testing the New Cabling
- Question Time

Close

1000Mb/s Implementation

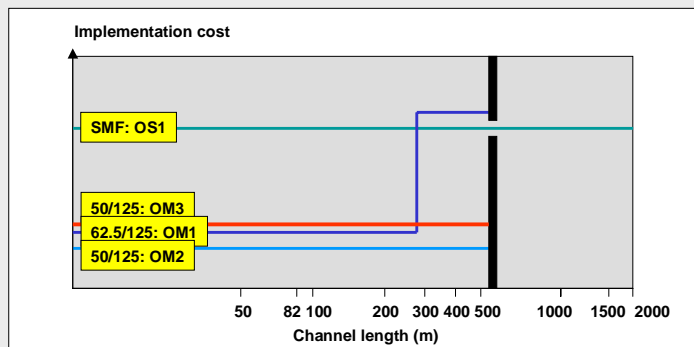

AGENDA

- Introduction
- A Standards Update
- Optical Fibre Categories
- Backwards Compatibility
- 10GBASE-xyz
- SFF Connecting Hardware
- Testing the New Cabling
- Question Time
- Close

10000Mb/s Implementation

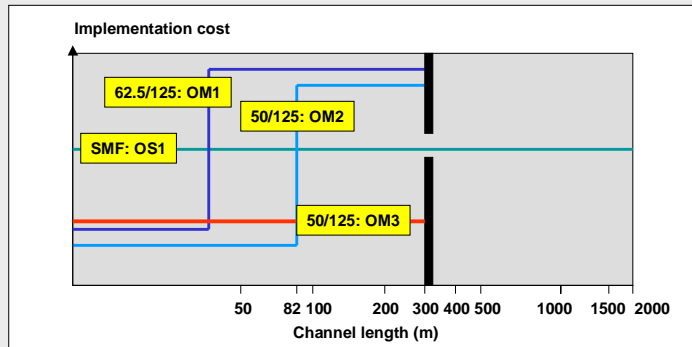

AGENDA

- Introduction
- A Standards Update
- Optical Fibre Categories
- Backwards Compatibility
- 10GBASE-xyz
- SFF Connecting Hardware
- Testing the New Cabling
- Question Time
- Close

SFF Connecting Hardware

IT CABLING STANDARDS			
	ISO/IEC 11801 Ed. 2 (2002)		EN 50173 Ed. 2 (2002)
	2nd CDV: Document N696		BS EN 50173 Ed. 2 (2002)

Mating dimensions and gauging of TO connection					
		Multimode OF		Singlemode OF	
		Connection	Splice	Connection	Splice
Return loss (dB min)	Wavelength	20dB	NA	35dB	NA
Attenuation (dB max)	All	95%<0.5	100%<0.3	95%<0.5	100%<0.3
		100%<0.75		100%<0.75	

Requirements for areas other than the telecommunications outlet

The optical fibre connectors used shall meet the requirements ..., with exception of the physical dimensions... In areas other than the work area, the choice of connecting hardware is open to all types of optical fibre connectors **standardized by IEC**.

When high density is an important consideration **Small Form Factor** connector designs that accommodate at least two fibres within the footprint of an EN 60603-7 connector are recommended.





However, where detail specifications produced by IEC or CENELEC in accordance with requirements of do not exist then **assurance should be sought from suppliers that the combinations of components** within connecting hardware are able to meet the optical and mechanical requirements of this clause.



AGENDA

- Introduction
- A Standards Update
- Optical Fibre Categories
- Backwards Compatibility
- 10GBASE-xyz
- SFF Connecting Hardware
- Testing the New Cabling
- Question Time
- Close

SFF Connecting Hardware

IT CABLING STANDARDS		
	ISO/IEC 11801 Ed. 2 (2002)	 EN 50173 Ed. 2 (2002)
	2nd CDV: Document N696	 6MP Document
		 BS EN 50173 Ed. 2 (2002)

Mating dimensions and gauging of TO connection					
		SC Duplex		IEC 60874-19-1	
		Multimode OF		Singlemode OF	
	Wavelength	Connection	Splice	Connection	Splice
Return loss (dB min)	All	20dB	NA	35dB	NA
Attenuation (dB max)	All	95%<0.5 100%<0.75	100%<0.3	95%<0.5 100%<0.75	100%<0.3

Requirements for areas other than the telecommunications outlet

The optical fibre connectors used shall meet the requirements with exception of the physical dimensions.... In areas other than the work area, the choice of connecting hardware is open to all types of optical fibre connectors **standardized by IEC**.

When high density is an important consideration **Small Form Factor** connector designs that accommodate at least two fibres within the footprint of an EN 60603-7 connector are recommended. However, where detail specifications produced by IEC or CENELEC in accordance with requirements of do not exist then **assurance should be sought from suppliers that the combinations of components** within connecting hardware are able to meet the optical and mechanical requirements of this clause.



AGENDA

- Introduction
- A Standards Update
- Optical Fibre Categories
- Backwards Compatibility
- 10GBASE-xyz
- SFF Connecting Hardware
- Testing the New Cabling
- Question Time
- Close

Symmetric and Asymmetric

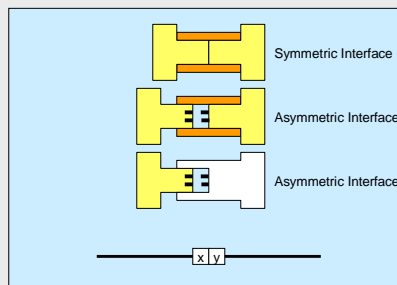

AGENDA

Introduction

- A Standards Update
- Optical Fibre Categories
- Backwards Compatibility
- 10GBASE-xyz
- SFF Connecting Hardware
- Testing the New Cabling
- Question Time

Close

Testing the New Cabling

Application			Optical Fibre			
			50/125 (OM2)		62.5/125 (OM1)	
Mb/s	Network	λ	Max. length (m)	OPB max. (dB)	Max. length (m)	OPB max. (dB)
4	Token Ring	850 nm	1857 ¹	8.0	2000	13.0
10	Ethernet		1514 ¹	6.8	2000	12.5
16	Token Ring		1857 ¹	8.0	2000	13.0
100	Ethernet	1300 nm	2000	6.0	2000	11.0
1000	Ethernet	850 nm	550	3.56	275	2.6
1000	Ethernet	1300 nm	550	2.35	550	2.35
10000	Ethernet	850 nm	82	1.80	33	1.60
10000	Ethernet	CWDM/850	300	2.46	300	2.46
			50/125 (OM3)			
10000	Ethernet	850 nm	300	2.59		

¹ Calculated values using 1.5dB of connecting hardware losses



AGENDA

Introduction

- A Standards Update
- Optical Fibre Categories
- Backwards Compatibility
- 10GBASE-xyz
- SFF Connecting Hardware
- Testing the New Cabling
- Question Time

Close

Link Configurations

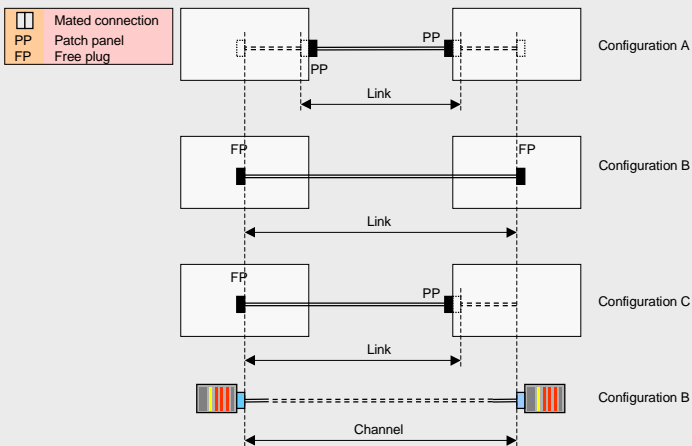

AGENDA

Introduction

- A Standards Update
- Optical Fibre Categories
- Backwards Compatibility
- 10GBASE-xyz
- SFF Connecting Hardware
- Testing the New Cabling
- Question Time

Close

Test Systems

EQUIPMENT TYPE	EQUIPMENT TYPE	GENERAL RULES
Uni-directional duplex		Link testing rules Configuration A: OK Configuration B: OK Configuration C: OK Channel tests: OK
Bi-directional duplex		Link testing rules Configuration A: test as channel Configuration B: OK Configuration C: test as channel Channel tests: OK



AGENDA

Introduction

- A Standards Update
- Optical Fibre Categories
- Backwards Compatibility
- 10GBASE-xyz
- SFF Connecting Hardware
- Testing the New Cabling
- Question Time

Close

Channel Tests

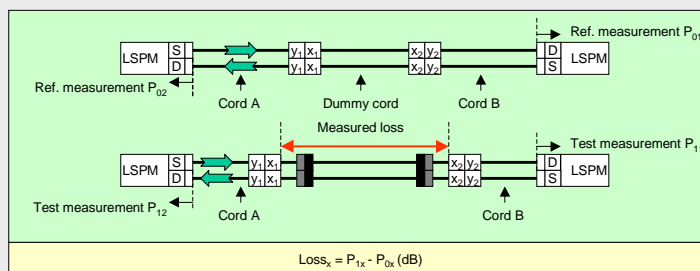

AGENDA

Introduction

- A Standards Update
- Optical Fibre Categories
- Backwards Compatibility
- 10GBASE-xyz
- SFF Connecting Hardware
- Testing the New Cabling
- Question Time

Close

Configuration A Links

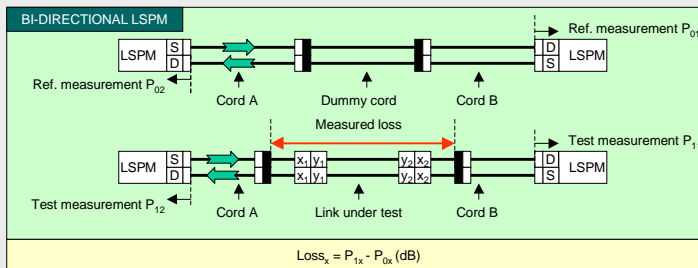

AGENDA

Introduction

- A Standards Update
- Optical Fibre Categories
- Backwards Compatibility
- 10GBASE-xyz
- SFF Connecting Hardware
- Testing the New Cabling
- Question Time

Close

Measurement Error

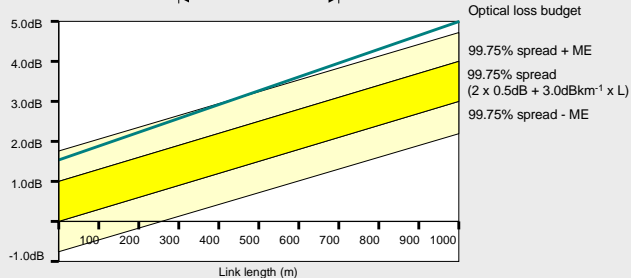
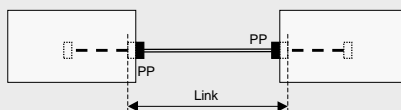

AGENDA

Introduction

- A Standards Update
- Optical Fibre Categories
- Backwards Compatibility
- 10GBASE-xyz
- SFF Connecting Hardware
- Testing the New Cabling
- Question Time

Close

Test Cords

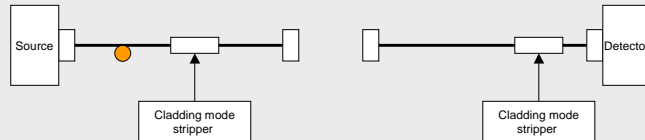

MMF LAUNCH CORD

Mandrel wrap and cladding mode stripper aim to present an equilibrium launch condition

MMF TAIL CORD

Cladding mode stripper provides "core only" light to detector
Removes requirement for bi-directional test



AGENDA

Introduction

- A Standards Update
- Optical Fibre Categories
- Backwards Compatibility
- 10GBASE-xyz
- SFF Connecting Hardware
- Testing the New Cabling
- Question Time

Close

MMF Mandrel Wrap

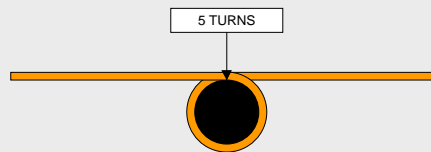

	MMF: not applicable		MMF: EN 50346 6MP		MMF: ANSI/TIA/EIA B.1		
		50/125	Cable	18	50/125	Cable	25
		50/125	SCOF	15	50/125	SCOF	22
		62.5/125	Cable	20	62.5/125	Cable	20
		62.5/125	SCOF	17	62.5/125	SCOF	17



AGENDA

Introduction

- A Standards Update
- Optical Fibre Categories
- Backwards Compatibility
- 10GBASE-xyz
- SFF Connecting Hardware
- Testing the New Cabling
- Question Time

Close

LASER LSPM Equipment

There is an argument to suggest that MMF cabling to support LASER-based applications should be tested with LASER sources

Reference measurement does not contain all modes.
Test measurement reads LOW.

Test results can vary with test lead handling.

Unless explicitly allowed and documented such equipment should not be used



AGENDA

Introduction

- A Standards Update
- Optical Fibre Categories
- Backwards Compatibility
- 10GBASE-xyz
- SFF Connecting Hardware
- Testing the New Cabling
- Question Time

Close

OTDR vs. LSPM

SHORT LENGTH SYNDROME
calls LSPM measurements into question
(unless measurement error is "allowed for" in adjudication)

OTDRs can be used to assess and measure individual components
(subject to appropriate techniques)

COMPONENT UP VERIFICATION MAY BECOME MORE COMMON



AGENDA

Introduction

- A Standards Update
- Optical Fibre Categories
- Backwards Compatibility
- 10GBASE-xyz
- SFF Connecting Hardware
- Testing the New Cabling
- Question Time

Close

FIA Documentation Update

DESIGN		
FIA-TSD-2000-1-1	OPTICAL FIBRE CABLING: LAN APPLICATION SUPPORT GUIDE	JANUARY 2001
	Revision to include mode conditioning cords and 10GBASE-xyz	JANUARY 2002
INSTALLATION		
FIA-TSD-2000-4-2-1	TESTING OF INSTALLED CABLING: ATTENUATION USING LSPM EQUIPMENT	JANUARY 2002
FIA-TSD-2000-4-2-2	TESTING OF INSTALLED CABLING: ATTENUATION USING OTDR EQUIPMENT	mid 2002
SAFETY		
FIA-TSD-2000-5-1	OPTICAL POWER: SAFETY LEVELS	DECEMBER 2001
FIA-TSD-2000-5-2	OPTICAL FIBRE: HANDLING OF PROCESSING CHEMICALS	
FIA-TSD-2000-5-3	OPTICAL FIBRE: DISPOSAL OF WASTE	
MODELLING TOOLS		
	CABLING STRUCTURES COST MODEL	DECEMBER 2001



AGENDA

Introduction

- A Standards Update
- Optical Fibre Categories
- Backwards Compatibility
- 10GBASE-xyz
- SFF Connecting Hardware
- Testing the New Cabling
- Question Time

Close

Question Time



The New Generation of Optical Fibre Components

Prepared and delivered for



Edinburgh Hilton
11th October 2001

